



## CONSTRUCTION METALLIQUE



*La force & la qualité le signe du succès*

## UNITÉS D'ALIMENT DE BETAIL FARINE

- UNITÉ DE FABRICATION D'ALIMENT POUR BETAILS VERTICAL de 0.5T à 2T/H:

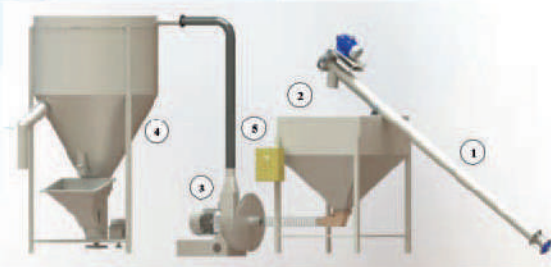

Réf	Désignation
1	Vis
2	Trémie
3	Broyeur
4	Mélangeur verticale
5	Armoire électrique

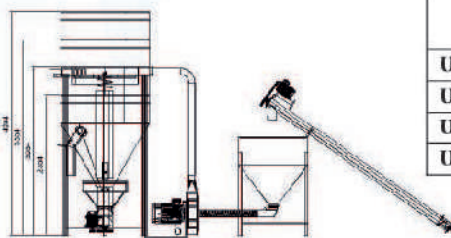

Réf	Vis		Broyeur	Mélangeur	
	Longueur (m)	Puissance (K w)	Puissance (K w)	Volume (m³)	Puissance (K w)
U.V 0.5	4	2.2	10/7.5	1.94	3
U.V 1	4	2.2	15/11	2.94	3
U.V1.5	6	3	15	3.94	4
U.V 2	6	3	22	4.94	5.5

- UNITE D'ALIMENT DU BETAILLE HORIZONTALE de 1T à 2T/H:

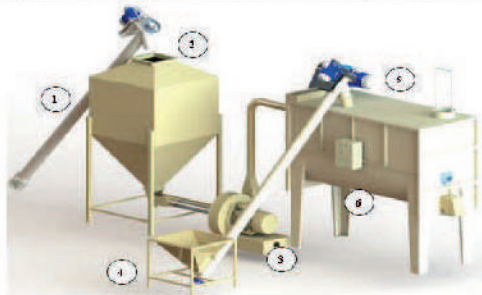

Rep	Désignation
1	vis
2	Trémie matière première
3	Broyeur
4	Trémie + Vis CMV
5	Mélangeur horizontale
6	Armoire électrique

Désignation	Vis	Broyeur	Vis CMV	Mélangeur
UH1 T	2.2 KW	15	2.2 KW	7.5KW
UH2 T	2.2 KW	17.5	2.2 KW	7.5KW

- UNITE D'ALIMENT DU BETAILLE HORIZONTALE de 3T à 5T:

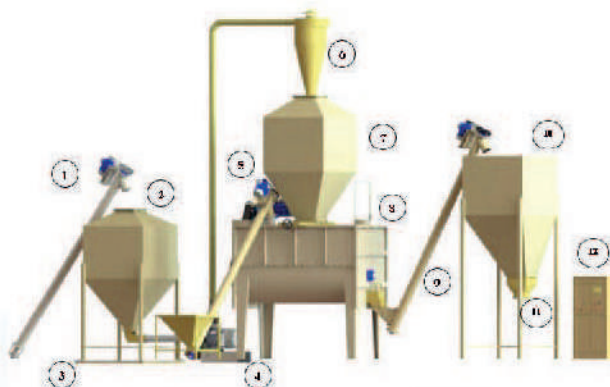

Rep	Désignation
1	3 vis
2	Pesage
3	Trémie matière première
4	Broyeur
5	Trémie + Vis CMV
6	cyclone
7	Trémie d'attente
8	Mélangeur horizontales
9	Vis ou <b>élevateur à godet</b>
10	Trémie matière finie
11	Trappe manuelle trémie matière finie ou <b>hacole</b> ensacheuse
12	Armoire électrique

Désignation	Vis	Broyeur	Vis CMV	Mélangeur
UH3T	2.2 KW	22KW	2.2 KW	7.5KW
UH4T	2.2 KW	30KW	2.2 KW	7.5KW
UH5T	2.2KW	37.5KW	2.2KW	7.5KW

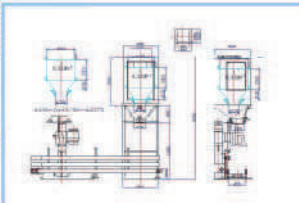
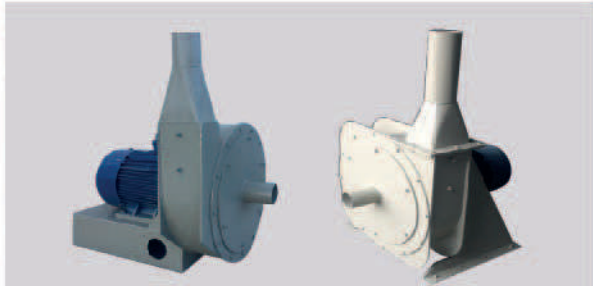

SOCIÉTÉ DE PRODUCTION MÉTALLIQUE DU SUD

La force & la qualité le signe du succès

## UNITÉ DE GRANULATION D'ALIMENT BÉTAIL

**SPM SUD** spécialisé dans la fabrication des équipements pour unité de granulation pour aliments de bétails.

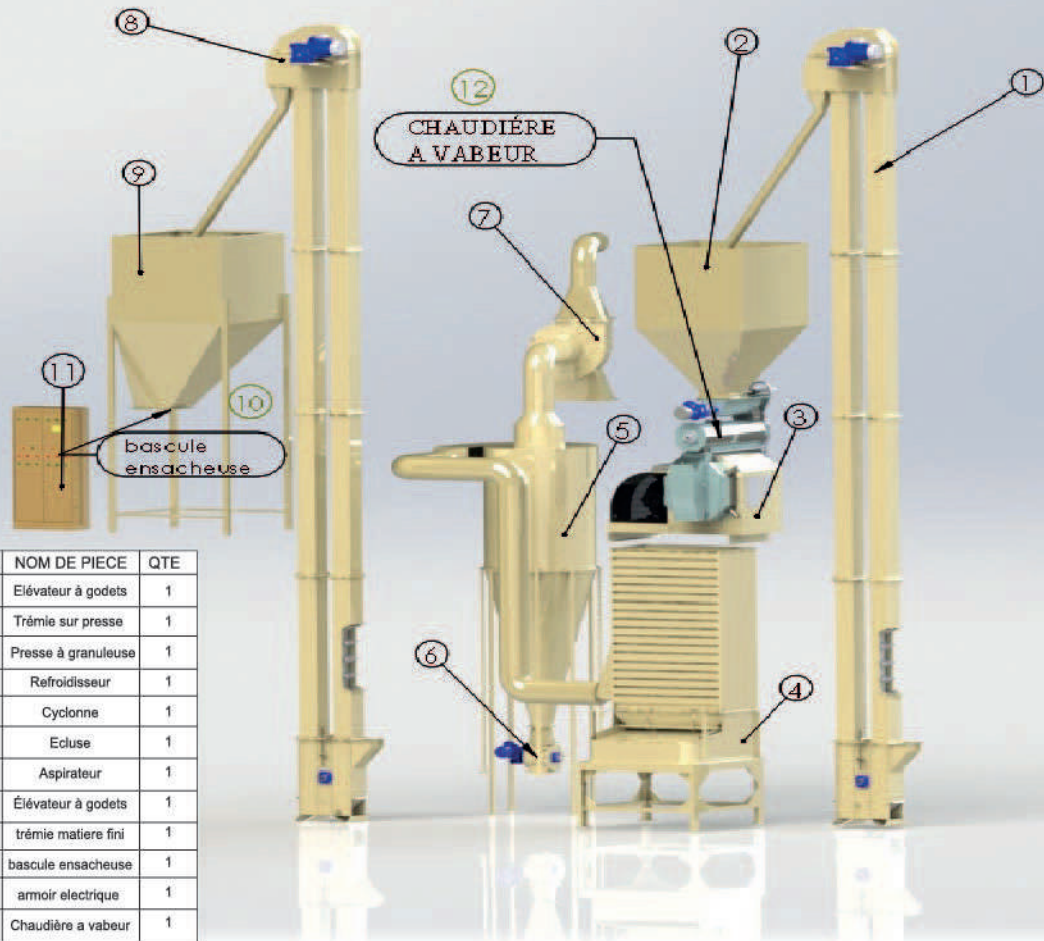

NO . ARTICLE	NOM DE PIECE	QTE
1	Élévateur à godets	1
2	Trémie sur presse	1
3	Presse à granuloseuse	1
4	Refroidisseur	1
5	Cyclonne	1
6	Ecluse	1
7	Aspirateur	1
8	Élévateur à godets	1
9	trémie matiere fini	1
10	bascule ensacheuse	1
11	armoir électrique	1
12	Chaudière a vapeur	1

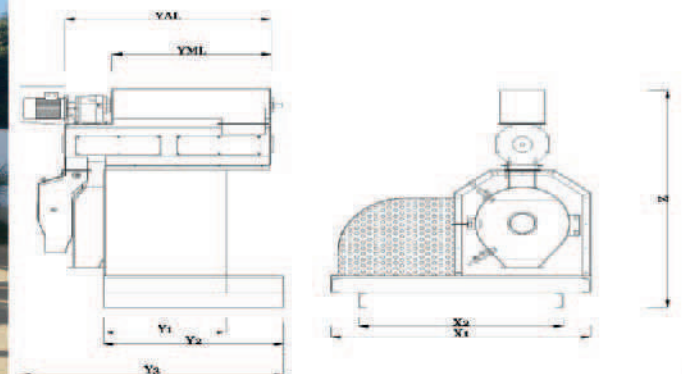

MODELE	DIMENSIONS(mm)							MOTEUR PRINCIPAL PUISSANCE(cv)	FILIERE DIAMETRE(mm)	CAPACITE ENVIRON (ton/h)	
	X1	X2	Z	Y1	Y7	Y3	Y4				
PA 03	1550	1400	1650	750	960	1300	1250	800	75	304	3
PA 05	1900	1500	2150	1000	1300	1800	1500	1150	120	420	5

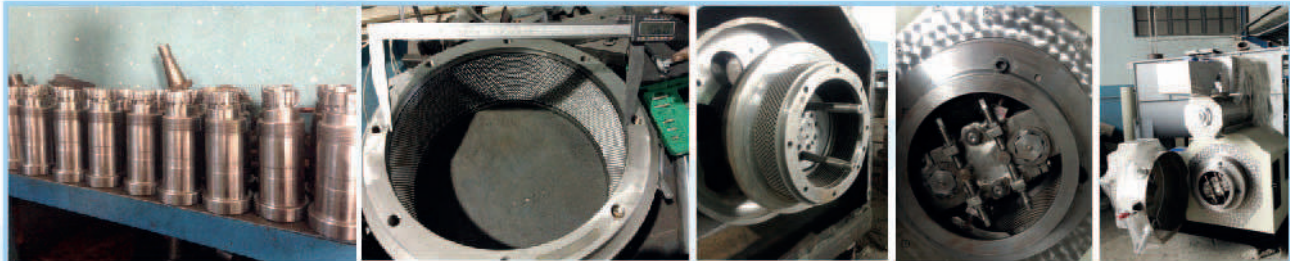

SOCIÉTÉ DE PRODUCTION MÉTALLIQUE DU SUD

La force & la qualité le signe du succès

## SILO DE STOCKAGE

**SPM SUD** fabrique des silos de stockage pour céréale, ciment, et de différents capacités à la demande du client.



SOCIETE DE PRODUCTION METALLIQUE DU SUD

*La force & la qualité le signe du succès*

## ELEVATEUR À GODETS

- 1) **SPM SUD** est spécialiste dans la fabrication des élévateurs à godets à différentes capacités en acier et en inox.

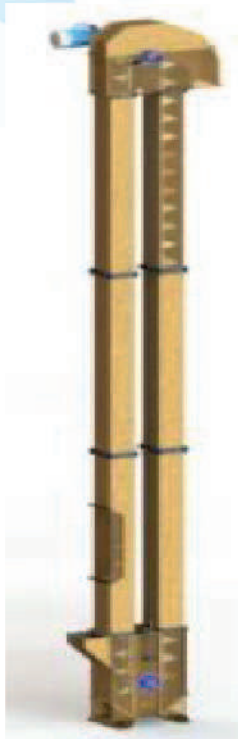

- 2) **SPM-SUD** fabrique par estampage les Dimensions des godets suivant :

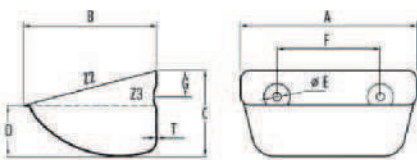

Type	A	B	C	D	E	V (l)	F
M10	107	90	67	50	7	0.3	58
M14	145	121	85	62	9	0.8	87
M18	185	142	88	65	9	1.3	100
M20	210	146	110	81	9	1.7	100

- 3) Des sangles selon demande : largeur (120 ;160;200)4plies ou bien 3plies et tout autres dimentions



*La force & la qualité le signe du succès*

## LES CONVOYEUR A VIS

**SPM SUD** fabrique les transmissions à vis de tout types en acier et en inox.

### 1. Type des convoyeurs à vis:



### 2. Transmission de mouvement:



### 3. Spire

Spire standard : longueur 3m

Ø ext.	Ø int.	pas	ep	
90	34	90	2/4	
100	34	100	2/4	2.5/5
120	42	120	2/4	2.5/5
130	42	130	2/4	2.5/5
160	60	160	2/4	2.5/5
180	60	180	2/4	2.5/5
200	60	200	2/4	2.5/5
230	60	230	2/4	2.5/5
250	60	250	2/4	2.5/5
300	89	300	2.5/5	

### spire sur commande

On fabrique différents dimensions de spires Ø plus de 500 mm et différents épaisseurs 4-6-8-10-12 et en acier et Inox.



Pour fourrage / transport ciment

### 4. Coussinets







Vis de forage



Vis Malaxeur



Vis Inox pour grinion

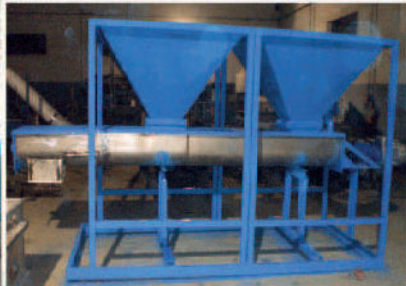

SOCIETE DE PRODUCTION METALLIQUE DU SUD

# TRANSPORTEUR À BANDE

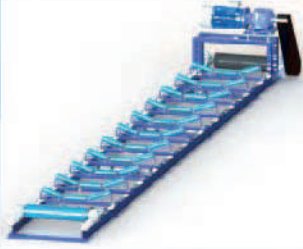

**SPMSud est spécialiste dans la fabrication des transporteurs à bande.**

Désignations	Moteur	Largeur bande	Type de bande	Vitesse
Tapie de 3m à 5m	2.2 KW	400	-à chevrons -lisse -PCV	Variable selon besoin et produit à transportée
Tapie 6m	2.2 KW	650/500		
Tapie 7m	2.2 KW			
Tapie 8m	3 KW	1000/800		
Tapie 9m	3 KW			
Tapie de 10m à 14m	-	1200		

- **Structure:**

Selon besoin: tubulaire /en Fer U / en tôle plier; ...

- Transporteur fixe
- Transporteur mobile sur deux roues
  - Réglable en hauteur {
    - par cable hydraulique
    - Centre
    - Pompe Mamll..



- **Support rouleau:**

				
Support à trois rouleaux	Support à deux rouleaux	Montage rouleaux	l'angle $\alpha$ est varié selon le besoin de client	Support auto centrage pour les tapis de longue distance

**SPMSud fabrique les Rouleaux pour les transporteurs à bande tout types.**

- **Les rouleaux:**

En fabrique les différents types de rouleau avec les diamètres suivant:  
48 ; 60 ; 63 ; 70 ; 76 ; 89 ; 114 ; 133 ; 139

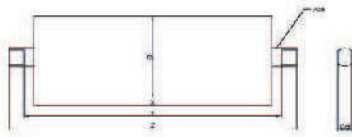

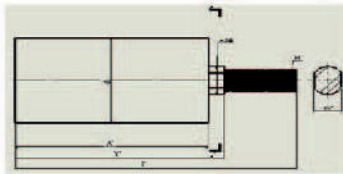

	validité	
	exemple	Validation du client
<b>Ø</b>	89	ok
<b>X</b>	240	ok
<b>Y</b>	270	ok
<b>Z</b>	290	ok
<b>ch</b>	14	ok
<b>axe</b>	20	ok

- **Rouleaux de guidage:**



	validité	
	exemple	Validation du client
<b>X'</b>	120	ok
<b>Y'</b>	130	ok
<b>Z'</b>	145	ok
<b>Ch'</b>	14	ok
<b>axe</b>	20	ok
<b>M</b>	16	ok

- **Rouleaux:**

Rouleaux anticollmatants	Rouleaux amortisseur				
					
	<table border="1"> <tr> <td>Bague en caoutchouc</td> </tr> <tr> <td>Ø 60/89</td> </tr> <tr> <td>Ø 63/89</td> </tr> <tr> <td>Ø 89/133</td> </tr> </table>	Bague en caoutchouc	Ø 60/89	Ø 63/89	Ø 89/133
Bague en caoutchouc					
Ø 60/89					
Ø 63/89					
Ø 89/133					

**SPMSud est spécialiste dans la fabrication des tambours.**

### Les tambours

En fabrique des tambours des transporteurs à bande

- { avec revêtement
- { lisse

Tambour arrière	Tambour avant
	

*La force & la qualité le signe du succès*

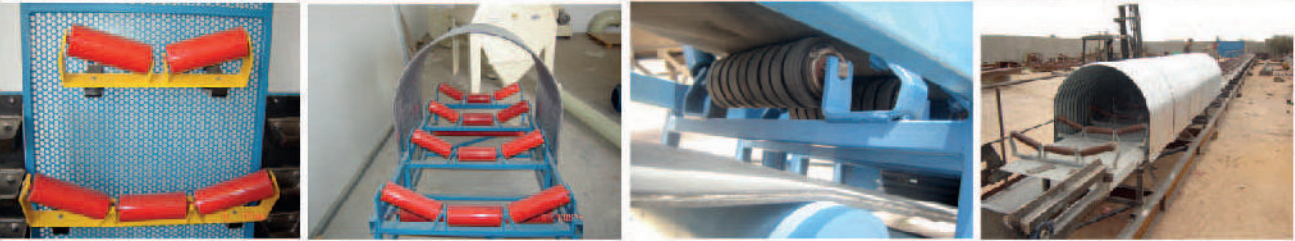

SOCIÉTÉ DE PRODUCTION MÉTALLIQUE DU SUD

*La force & la qualité le signe du succès*

## UNITÉ DE NETTOYAGE DES GRINIONS FRAIS

**SPM SUD** spécialisé dans la fabrication des équipements pour nettoyage des grinions frais 50 % d'humidité.



1	Tremis avec variation de fréquence
2	Transporteur à bande
3	Aimant permanent
4	Tamis rotatif grande maille
5	Vis de malaxage
6	Malaxeur 2000 litres
7	Tamis rotatif petite maille EXV
8	Pompe à piston
9	Dénoyauteuse



SOCIÉTÉ DE PRODUCTION MÉTALLIQUE DU SUD

**SPM SUD** spécialisé dans la fabrication des aspirateurs de grand tailles suivant demande .



**SPM SUD** spécialisé dans la fabrication des tamis rotatif.



MODELE	DIMENSIONS (mm)					MOTEUR	Tamie
	X	Y1	Y2	Z1	Z2	PUISSANCE (kw)	DIAMETRE (mm)
TR 600	1000	1800	2000	2700	2000	2.2	600
TR800	1110	2250	2400	3260	2500	3	800
TR 1000	1250	2500	2700	3700/5000	2500/4000	4	1000
TR 1200	1500	2800	3000	3700/5500	2500/4500	5.5	1200

*La force & la qualité le signe du succès*

## TRAVAUX DE CHAUDRONNERIE

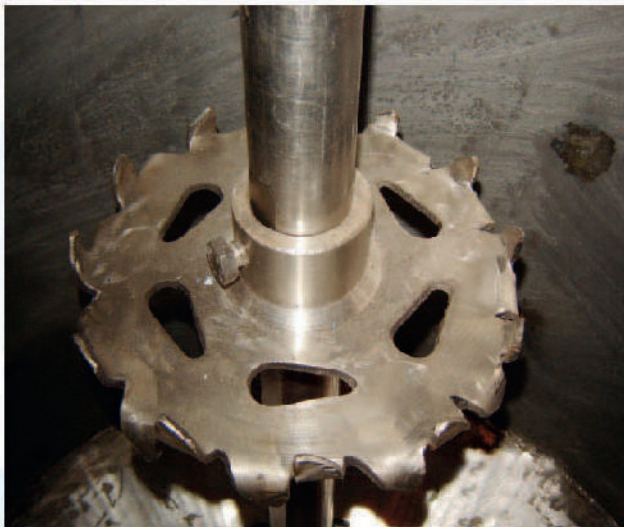
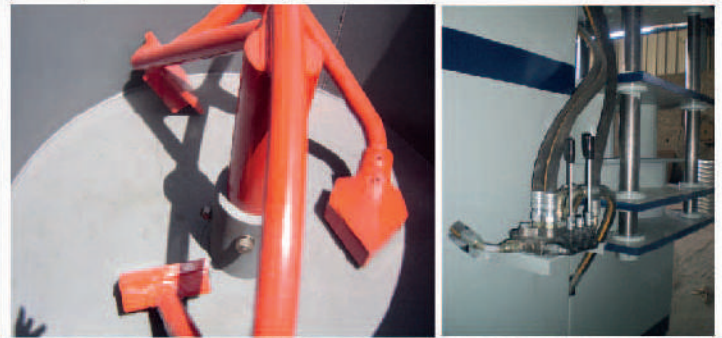

SOCIÉTÉ DE PRODUCTION MÉTALLIQUE DU SUD

## CHARPENTES MÉTALLIQUES

**SPM SUD** est spécialisé pour la fabrication et montage des charpentes métalliques.

### Charpente



### Charpente avec revêtement en panneaux ↓



### Charpente Omega ↓



*La force & la qualité le signe du succès*

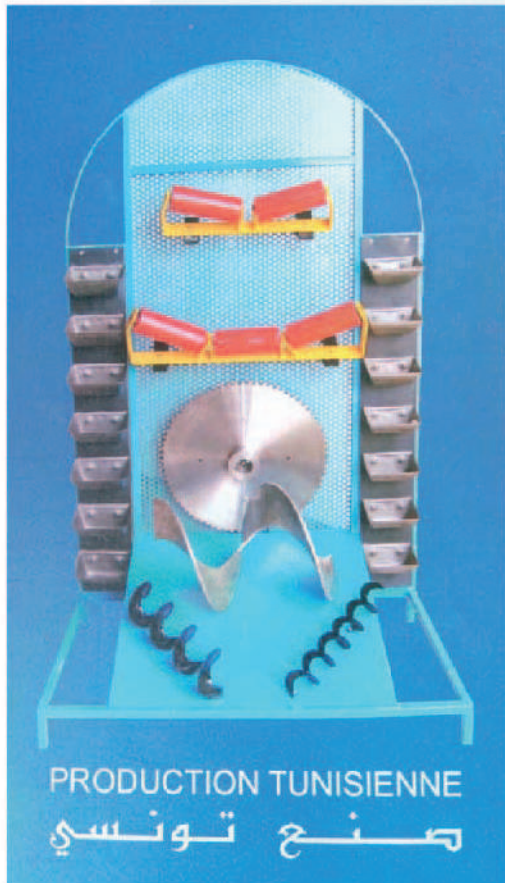

المقر الإجتماعي : طريق المهديّة كلم 10  
Siège social : Route mahdia km 10 Sfax  
الهاتف: (216) 74 830 433 / 74 832 477  
Tél. : (216) 74 830 433 / 74 832 477  
الجوال: 98 761 222 / 98 761 224  
Mob. : 98 761 222 / 98 761 232  
الفاكس: (216) 74 832 470  
Fax : (216) 74 832 470  
البريد الإلكتروني: spmsud@gnet.tn  
Email : spmsud2019@gmail.com



SPMSUD

(216) 74 832 470